

Series 3A & 3AH Double Flange

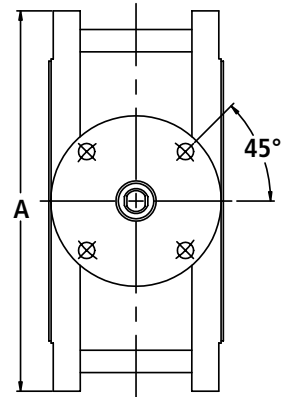
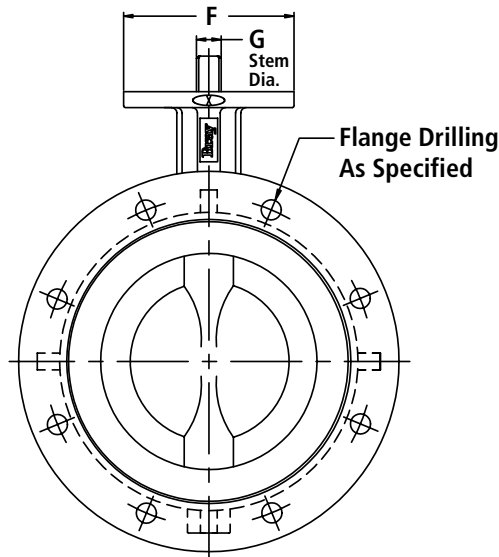
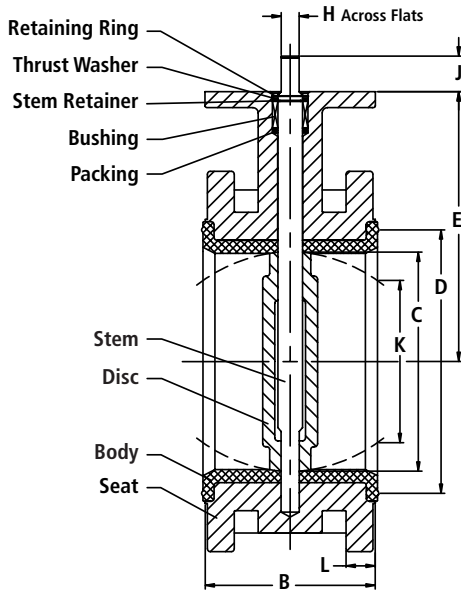

IMPERIAL DIMENSIONS: Inches

Valve Size	A	B	C	D	E	F	Top Plate Drilling			G	H	J	K	L	Adapter Code	Weight (lbs.)	Flange Bolting Data		
							BC	No of Holes	Hole Diameter								Bolt Circle	No of Holes	Threads ISO Coarse
2	6.50	4.25	2.00	2.84	5.50	3.54	2.76	4	.39	.55	.39	1.25	N/A	.79	A	22	4.75	4	5/8-11
2.5	7.28	4.41	2.50	3.34	6.00	3.54	2.76	4	.39	.55	.39	1.25	N/A	.79	A	24	5.50	4	5/8-11
3	7.87	4.49	3.00	4.03	6.25	3.54	2.76	4	.39	.55	.39	1.25	N/A	.87	A	28	6.00	4	5/8-11
4	8.66	5.00	4.00	5.16	7.00	3.54	2.76	4	.39	.63	.43	1.25	N/A	.95	B	35	7.50	8	5/8-11
5	9.84	5.51	5.00	6.16	7.50	3.54	2.76	4	.39	.75	.51	1.25	N/A	1.03	C	45	8.50	8	3/4-10
6	11.22	5.51	5.75	7.02	8.00	3.54	2.76	4	.39	.75	.51	1.25	1.78	1.03	C	59	9.50	8	3/4-10
8	13.50	5.98	7.75	9.47	9.50	5.91	4.92	4	.57	.87	.63	1.25	5.00	1.18	D	70	11.75	8	3/4-10
10	15.94	6.50	9.75	11.47	10.75	5.91	4.92	4	.57	1.18	.87	2.00	7.35	1.26	E	132	14.25	12	7/8-9
12	19.00	7.01	11.75	13.47	12.25	5.91	4.92	4	.57	1.18	.87	2.00	9.53	1.26	E	178	17.00	12	7/8-9

Note: K dimension is disc chordal dimension at valve face.

METRIC DIMENSIONS: Millimeters

Valve Size	A	B	C	D	E	F	Top Plate Drilling			G	H	J	K	L	Adapter Code	Weight (kg)	Flange Bolting Data		
							BC	No of Holes	Hole Diameter								Bolt Circle	No of Holes	Threads ISO Coarse
50	165	108	51	72	140	90	70	4	9.9	14	10	32	N/A	20	A	10	121	4	5/8-11
65	185	112	64	85	152	90	70	4	9.9	14	10	32	N/A	20	A	11	140	4	5/8-11
80	200	114	76	102	159	90	70	4	9.9	14	10	32	N/A	22	A	13	152	4	5/8-11
100	220	127	102	131	178	90	70	4	9.9	16	11	32	N/A	24	B	16	191	8	5/8-11
125	250	140	146	178	203	90	70	4	9.9	19	13	32	N/A	26	C	20	216	8	3/4-10
150	285	140	146	178	203	90	70	4	9.9	19	13	32	45	26	C	27	241	8	3/4-10
200	343	152	197	241	241	150	125	4	14.5	22	16	32	127	30	D	32	298	8	3/4-10
250	405	165	248	291	273	150	125	4	14.5	30	22	51	187	32	E	60	362	12	7/8-9
300	483	178	298	342	311	150	125	4	14.5	30	22	51	242	32	E	81	432	12	7/8-9

Note: K dimension is disc chordal dimension at valve face.

Drawings are for reference only. Please refer to Bray ES drawings on the Bray website, www.bray.com. Bray reserves the right to change product dimensions without notice.

Inquire/P.O. No.: _____

Bray Order No.: _____

SR Drawing #3A/3AH-2/12-in

Customer/Project: _____

Series 3A & 3AH Double Flange

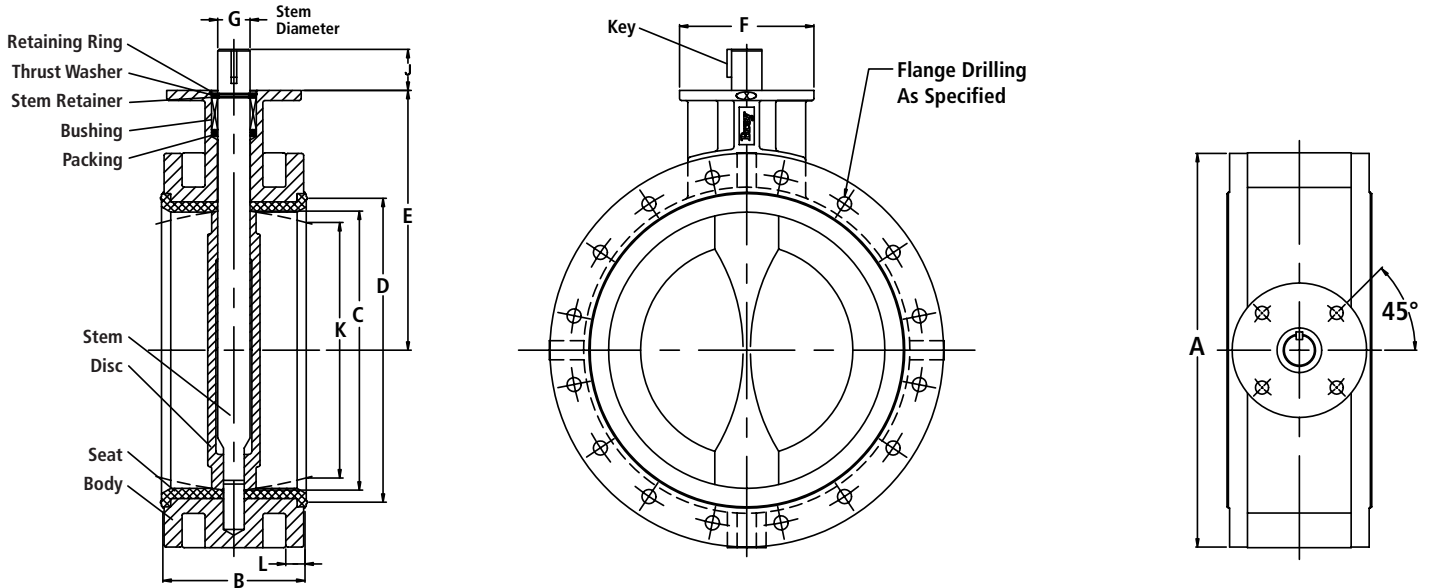

IMPERIAL DIMENSIONS: Inches																	Flange Bolting Data		
Valve Size	A	B	C	D	E	F	Top Plate Drilling			G	Key Size	J	K	L	Adapter Code	Weight (lbs.)	Bolt Circle	No of Holes	Threads ISO Coarse
							BC	No of Holes	Hole Diameter										
14	21.00	7.48	13.25	15.28	13.62	5.91	4.92	4	.57	1.38	.39x.39	2.00	11.07	1.42	F	258	18.75	12	1-8
16	23.50	8.51	15.25	17.41	14.75	5.91	4.92	4	.57	1.38	.39x.39	2.00	12.81	1.50	F	318	21.25	16	1-8
18	25.20	8.74	17.25	19.47	16.00	8.27	6.50	4	.81	1.97	.47x.39	2.50	15.02	1.65	G	459	22.75	16	1 1/8-7
20	28.15	9.02	19.25	21.29	17.25	8.27	6.50	4	.81	1.97	.47x.39	2.50	17.15	1.65	G	534	25.00	20	1 1/8-7

Note: K dimension is disc chordal dimension at valve face.

METRIC DIMENSIONS: Millimeters																	Flange Bolting Data		
Valve Size	A	B	C	D	E	F	Top Plate Drilling			G	Key Size	J	K	L	Adapter Code	Weight (kg.)	Bolt Circle	No of Holes	Threads ISO Coarse
							BC	No of Holes	Hole Diameter										
350	533	190	337	388	346	150	125	4	14	35	10x10	51	281	36	F	117	476	12	1-8
400	597	216	387	442	375	150	125	4	14	35	10x10	51	325	38	F	144	540	16	1-8
450	640	222	438	495	406	210	165	4	21	50	12x10	64	381	42	G	208	578	16	1 1/8-7
500	715	229	489	548	438	210	165	4	21	50	12x10	64	436	42	G	242	635	20	1 1/8-7

Note: K dimension is disc chordal dimension at valve face.

Drawings are for reference only. Please refer to Bray ES drawings on the Bray website, www.bray.com. Bray reserves the right to change product dimensions without notice.

SR Drawing #3A/3AH-14/20-in

Inquire/P.O. No.: _____

Customer/Project: _____

Bray Order No.: _____